

F316 TRIM#12

Fig No: **FGB-1500**

MATERIALS LIST

NO.	NAME	MATERIAL
1	BODY	ASTM A182 Gr.F316
4	DISC	ASTM A182 Gr.F316
5	STEM	ASTM A182 Gr.F316
9	BONNET	ASTM A182 Gr.F316
11	BODY SEAL	SS316L+GRAPHITE
14	STEM PACKING	FLEXIBLE GRAPHITE
15	GLAND	ASTM A276 Gr.316
16	GLAND NUT	ASTM A194 Gr.8
18	YOKE SLEEVE	ASTM A276 Gr.410
19	HANDWHEEL	ASTM A197
23	HANDLE WASHER	STAINLESS STEEL
24	H.W.NUT	ASTM A194 Gr.8
25	NAMEPLATE	SS304
35	BODY BOLT	ASTM A193 Gr.B8
42	GLAND BOLT	ASTM A193 Gr.B8
47	GLAND FLANGE	ASTM A182 Gr.F316

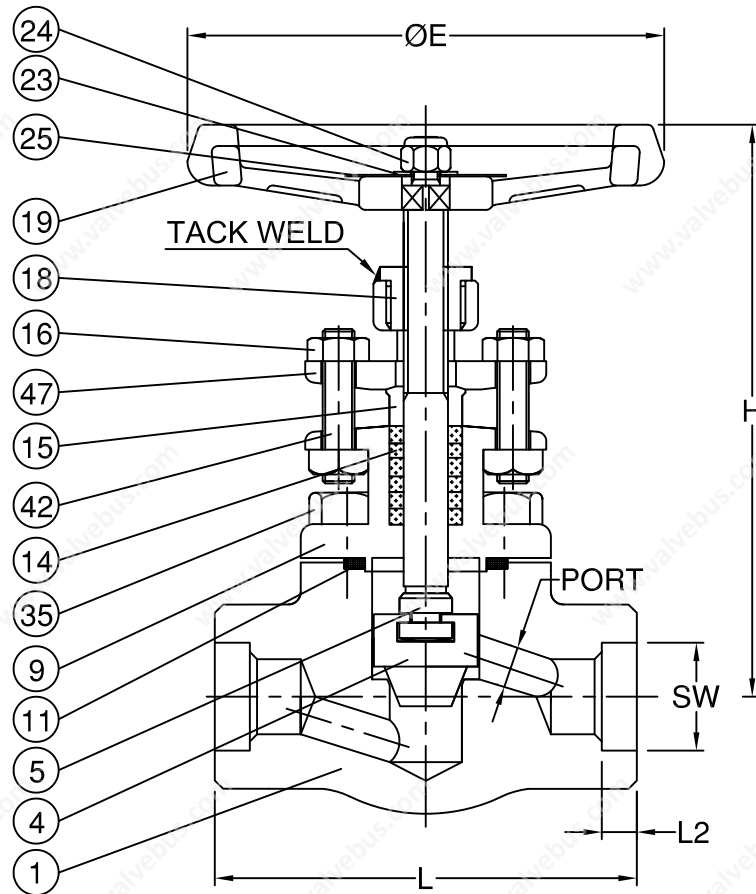

The basic design is according to API602

DIMENSIONS

unit:mm

SIZE	PORT	L	L2	ØE	H	SW	
DN8	1/4"	6.0	79.0	10.0	95.0	168.0	14.2
DN10	3/8"	6.0	79.0	10.0	95.0	168.0	17.6
DN15	1/2"	10.0	92.0	10.0	95.0	170.0	21.8
DN20	3/4"	13.0	111.0	13.0	120.0	205.0	27.2
DN25	1"	17.5	120.0	13.0	150.0	233.0	33.9
DN40	1-1/2"	28.6	172.0	13.0	170.0	282.0	48.8
DN50	2"	32.0	180.0	16.0	200.0	312.0	61.2

CODE	L-018	APPROVED BY.	CHECK BY.	DRAWN BY.	DRAWING NO.	MATERIAL	UNIT	DESCRIPTION
	SIGN	MIKE	JERRY	DATE	FGB-1500-L018	MATERIALS LIST	mm	FORGED STEEL GLOBE VALVE, SOCKET WELDING END , ANSI CLASS 1500
	DATE	12/14/2010	12/14/2010	07/30/2010	REVISION	01	SCALE	