

Fig No: **FGB-2500**

MATERIALS LIST

NO.	PART NAME	MATERIAL
1	BODY	ASTM A182 Gr.F316
4	DISC	ASTM A182 Gr.F316
5	STEM	ASTM A182 Gr.F316
9	BONNET	ASTM A182 Gr.F316
15	GLAND	ASTM A276 Gr.316
16	GLAND NUT	ASTM A194 Gr.8
17	GLAND PACKING	FLEXIBLE GRAPHITE
19	HANDWHEEL	ASTM A197
22	STEM NUT	ASTM A276 Gr.410
23	H/W WASHER	SS
24	H/W NUT	ASTM A194 Gr.8
25	NAMEPLATE	SS
42	GLAND BOLT	ASTM A193 Gr.B8
44	P.S. LOCK NUT	ASTM A276 Gr.316
47	GLAND FLANGE	ASTM A182 Gr.F316
57	P.S. RING	ASTM A276 Gr.316
61	STUFF BOX	ASTM A182 Gr.F316
64	SPACER	ASTM A276 Gr.316
78	BRACKET	ASTM A276 Gr.316

DIMENSIONS

		unit:mm				
SIZE	PORT	L	ØE	H		
DN20	3/4"	12.0	155.0	200.0	293.0	
DN25	1"	17.5	186.0	220.0	320.0	

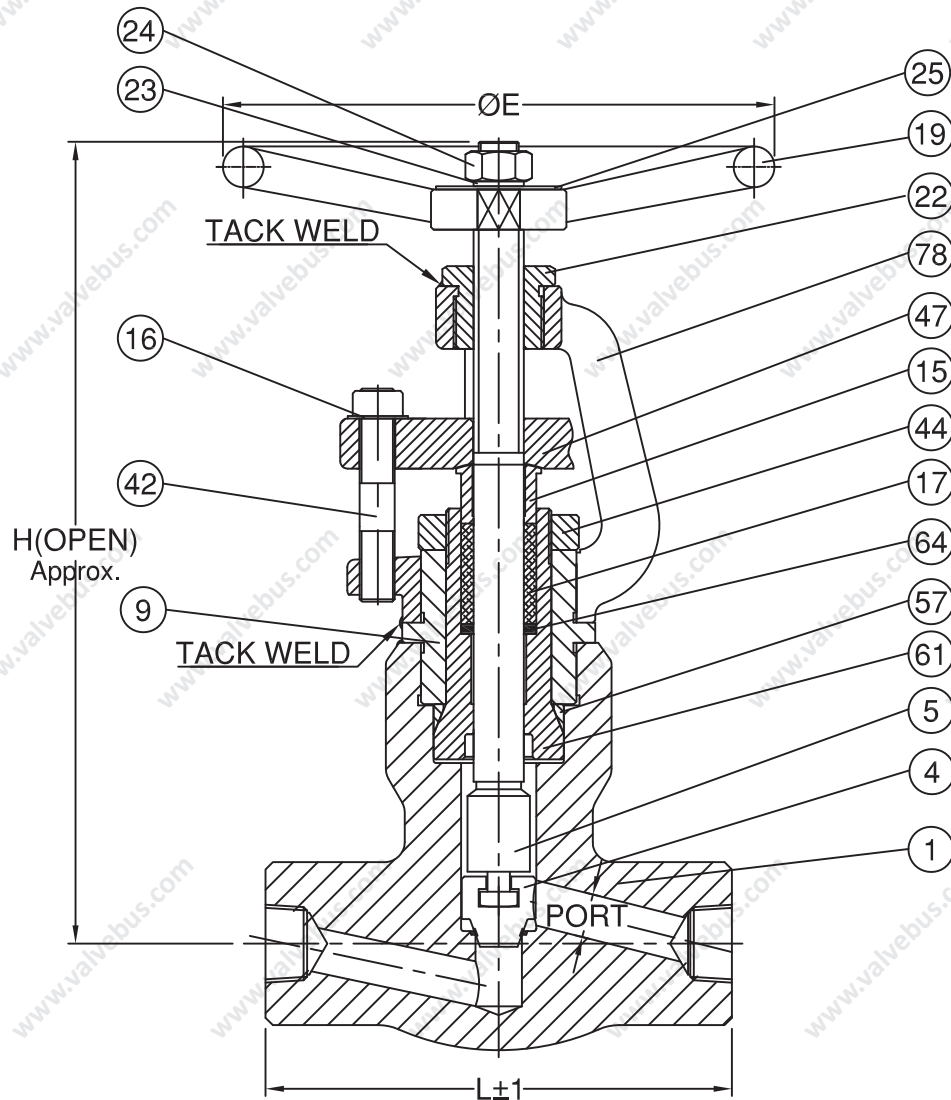

CODE	L-018		APPROVED BY.	CHECK BY.	DRAWN BY.	DRAWING NO.	MATERIAL	UNIT	DESCRIPTION
	SIGN	MIKE	JERRY	JERRY	FGB-2500-L018	MATERIALS LIST	mm	FORGED STEEL GLOBE VALVES, THREADED END, ANSI CLASS 2500	
	DATE	07/08/2011	07/08/2011	07/08/2011	REVISION	01	SCALE		FREE

Fig No: FGB-2500

MATERIALS LIST

NO.	PART NAME	MATERIAL
1	BODY	ASTM A182 Gr.F316
4	DISC	ASTM A182 Gr.F316
5	STEM	ASTM A182 Gr.F316
9	BONNET	ASTM A182 Gr.F316
11	GASKET	ASTM A276 Gr.316
15	GLAND	ASTM A276 Gr.316
16	GLAND NUT	ASTM A194 Gr.8
17	GLAND PACKING	FLEXIBLE GRAPHITE
18	NUT	ASTM A276 Gr.316
18-1	NUT SLEEVE	ASTM A276 Gr.316
19	HANDWHEEL	ASTM A197
20	BOLT	ASTM A194 Gr.8
22	STEM NUT	BRONZE
24	H/W NUT	ASTM A194 Gr.8
42	GLAND BOLT	ASTM A193 Gr.B8
44	NUT	ASTM A276 Gr.316
47	GLAND FLANGE	ASTM A182 Gr.F316
54	LANTERN RING	ASTM A276 Gr.316
56	BEARING	GCr15
57	SEALING RING	ASTM A276 Gr.316
61	STUFF BOX	ASTM A182 Gr.F316
64	SPACER	ASTM A276 Gr.316
74	LOCATING PLATE	ASTM A182 Gr.F316
74-1	LOCATING PLATE	ASTM A182 Gr.F316
78	YOKE	ASTM A276 Gr.316

DIMENSIONS

unit:mm					
SIZE	PORT	L	ØE	H	
DN32	1-1/4"	22.5	232.0	300.0	491.0
DN40	1-1/2"	28.5	232.0	300.0	491.0
DN50	2"	35.0	279.0	350.0	544.0

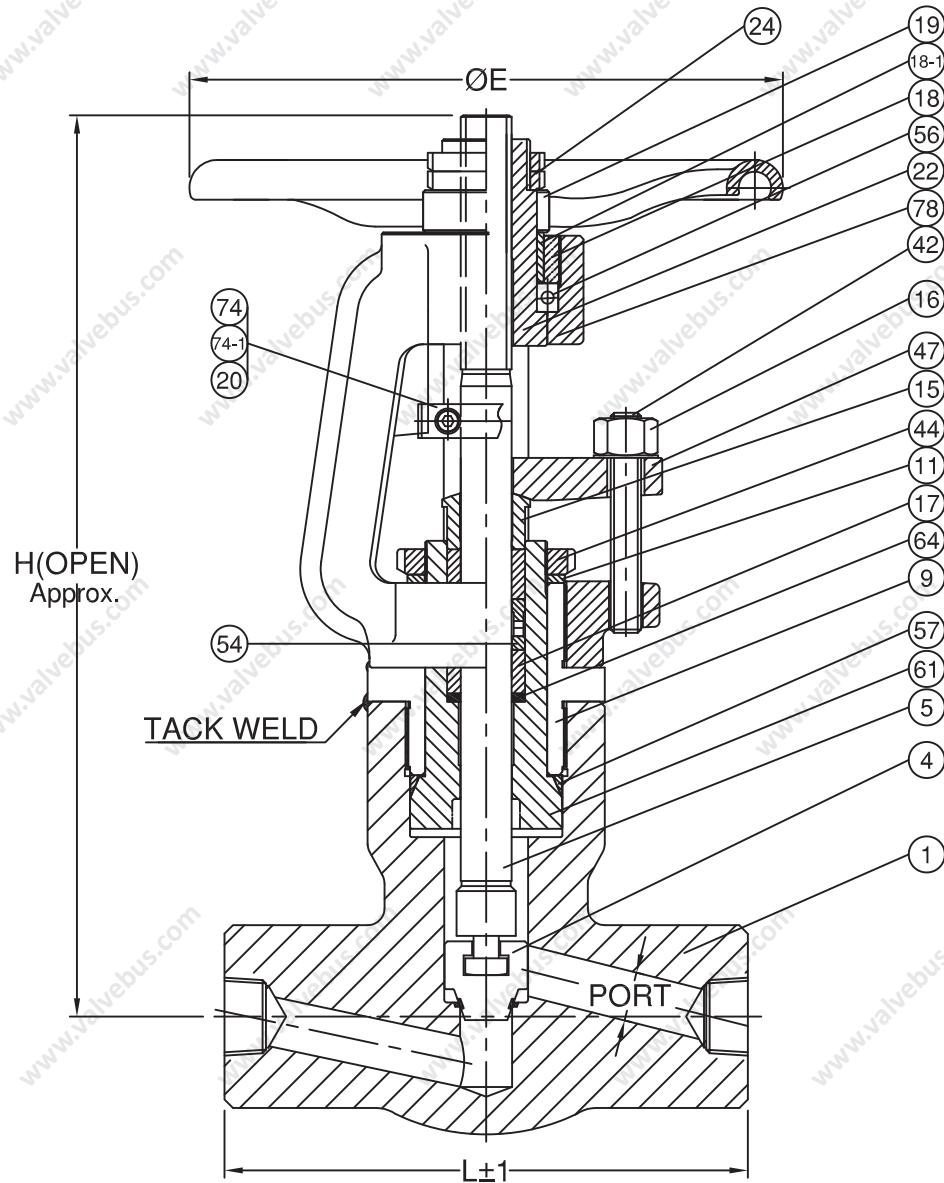

CODE	L-018		APPROVED BY.	CHECK BY.	DRAWN BY.	DRAWING NO.	MATERIAL	UNIT	DESCRIPTION
	SIGN	MIKE	JERRY	JERRY	FGB-2500-L018	MATERIALS LIST	mm	FORGED STEEL GLOBE VALVES, THREADED END, ANSI CLASS 2500	
	DATE	07/08/2011	07/08/2011	07/08/2011	REVISION				01