

General information

A routine maintenance or lubrication of the triple offset butterfly valve HGT is not necessary. Should a leakage occur at the gland packing, retighten the gland nut (21). Take care that the gland nut is not tightened too much. Normally the leakage can be stopped by simply turning the nut by a quarter.

Replacing the Gland Packing

If the leakage cannot be stopped using the above method, the gland packing must be replaced. For replacing the gland packing it is not necessary to remove the valve from the pipeline.

- Check whether the pipeline has been rendered depressurized and is empty.
- Remove the operating element.
- Loosen the fixing devices (19, 20, 21) of the gland flange and lift off the gland flange (9).
- Remove the gland (8). A groove in the upper part of the gland makes the removal easier.
- Remove the packing rings (6) and thoroughly clean the area of the gland packing.
- Insert a new packing set, whereby it is to be ensured that the correct packing material is used.
- Insert the gland, place the gland flange on top and fix it using the screws, nuts and split washers. Tighten the nuts alternately so that the gland flange is not tilted. Only slightly tighten the nuts until the leakage is stopped.

Replacing the Seat

In order to ensure that the valve works safely, we highly recommend to order the replacing of the seat at the factory of GEFA Processtechnik GmbH. If the changing of the seat is not carried out by our staff, we will not assume any liability for the correct working of the valve.

The valve must be taken out of the pipeline for replacing the seat.

- Ensure that the pipeline is rendered depressurized and is empty.
- Completely close the valve, loosen the flange screws and remove them so far that the valve can be taken out.
- Lay the valve down with the insert ring (7) facing upwards so that the valve's actuator connection is in a 12 o' clock position. The flat sealing surface of the disc is now on the left-hand side.
- Unscrew the cylinder screws (16) and lift the insert ring out of the body.
- Remove the old seat (4). Clean the body, insert ring and disc in the area of the seat-engaging surface.
- Bring the disc exactly into 'CLOSED' position. For this, the front side of the disc must be parallel to the seat contact surface.
- In the area of the seat contact surface the body (1) has 3 center holes ($\varnothing 2$ mm). The holes are arranged on top (12 o' clock), at the bottom (6 o' clock) and on the left-hand side (9 o' clock). Insert the new seat (4) in such a way that the holes in the seat are congruent with the center holes in the body. Now the sealing surface of the seat must fully lie against the disc.
- The insert ring is equipped with 2 opposing threaded holes. Another threaded respectively center hole is displaced at 90° to these threaded holes. The insert ring is to be placed into the body in such a way that the opposing threaded holes are in the 12 o' clock and 6 o' clock positions and the third hole is in the 9 o' clock position (left-hand side).
- Insert the cylinder screws (16) and slightly tighten them alternately.
- Carefully open and close the valve 5 times to allow the seat to centre itself. Whilst actuating the valve, it may be necessary to increase the force with each closing operation in order to ensure the exact position of the seat.
- Tighten the screws of the insert ring alternately, using following torque:
 $M5 = 6 \text{ Nm}$ $M6 = 10 \text{ Nm}$
- In order to achieve an optimum seat tightness, the seat has to be forced once. For this purpose, the insert ring has to be pushed against the body, using the following force:

DN	80	100	125	150	200	250	300
Force [kN]	60	70	90	100	150	200	240

If no corresponding compactor is available, the seat can also be forced by installing it between 2 flanges. Using this method care should be taken that a ring (or a disc) has to be laid on the insert ring, that has a slightly smaller outside diameter than the outside diameter of the insert ring is. Tighten the flange screws alternately with the following torque (that apply to DIN PN 10 flanges):

DN	80	100	125	150	200	250	300
Tightening torque [Nm]	22	25	35	45	65	65	75

Ensure that the pressure is evenly applied to the insert ring.

- After having forced the seat, alternately retighten the screws of the insert ring with the following torque:
 $M5 = 6 \text{ Nm}$ $M6 = 10 \text{ Nm}$
- Pressure-test the valve.

Mounting of the Mounting Plate

- Fit the mounting plate (22) and fix it using the screws (23).
Danger: GEFA original screws (23) MUST be used. Using other screws may cause injury or death to people as well as serious damage to the valve and other physical objects belonging to the operator.
- If required, push the square adapter onto the shaft. If necessary, use adequate means to ensure that the square adapter will not slip off the stem.

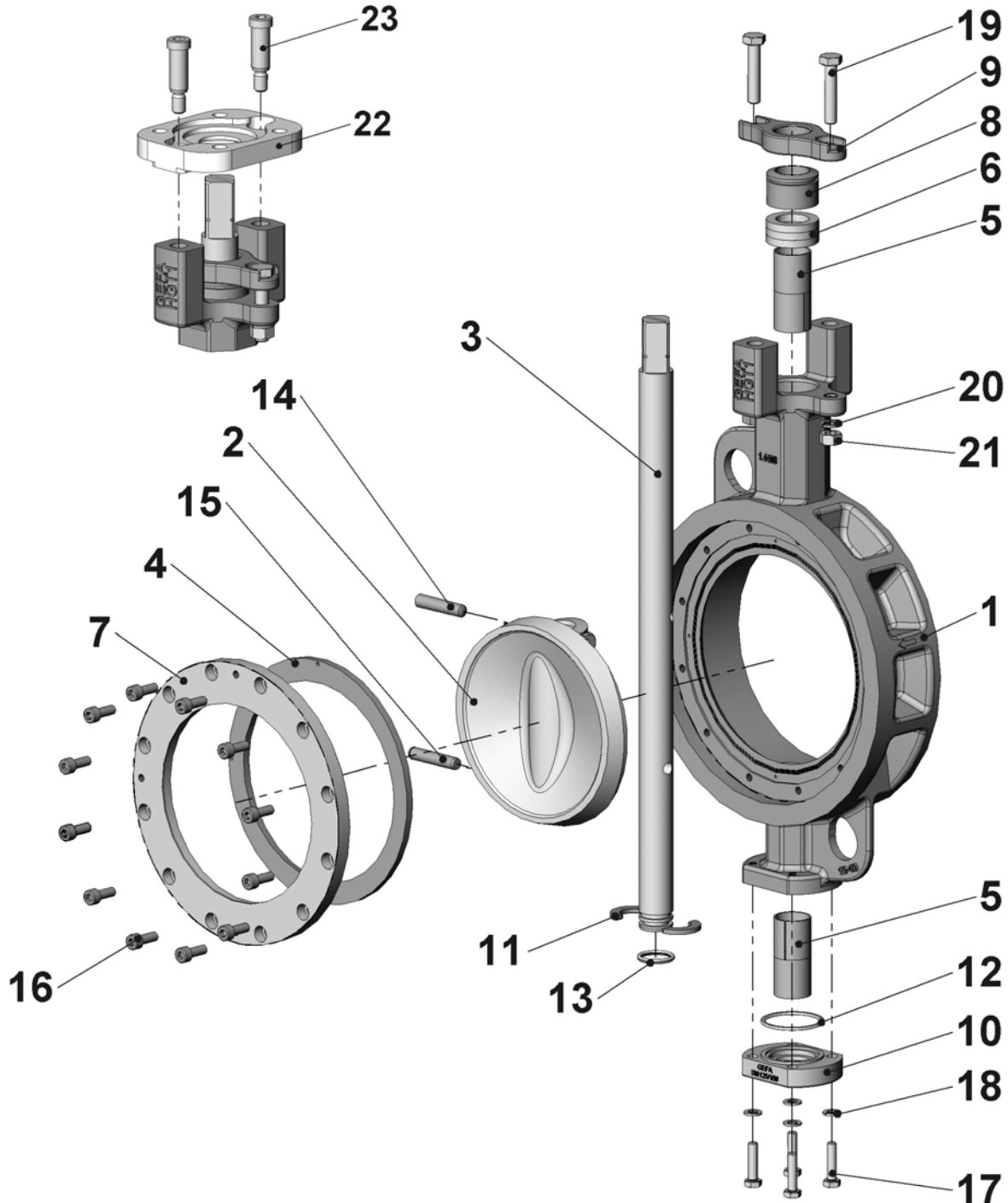

1 Body	7 Insert ring	13 O-ring	19 Hexagon screw
2 Disc	8 Gland	14 Tapered pin	20 Split washer
3 Stem	9 Gland flange	15 Straight pin	21 Hexagon nut
4 Seat	10 Bottom flange	16 Cylinder screw	22 Mounting plate
5 Bearing	11 Axial securing device	17 Hexagon screw	23 Fixing screw
6 Gland packing	12 Bottom flange seal	18 Split washer	

Subject to modifications without notice

Edition: 2012-05-07