



**GEFA Valves
for Biogas plants fulfils
the users' highest requirements**

DOMINO knife gate valves Type AT 100/200: High security by cutting effect
with the closing procedure

Butterfly valves Type KG 2/4: High life span by solid seat system

Valves for Substrate and Biogas

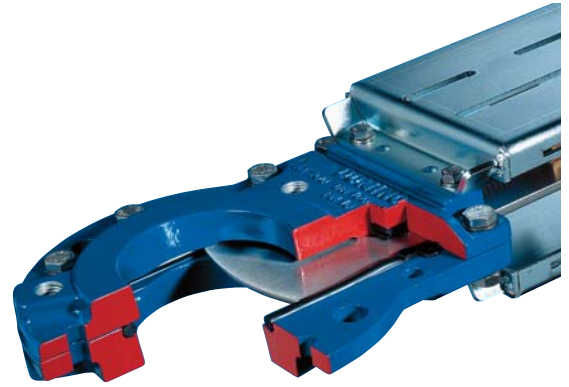

Executions

Body: Cast iron GG-25, EKB-coated (option GGG 40)
 Gate: 1.4301 (option 1.4571)
 Seal: NBR, EPDM, FPM, MVQ, PTFE
 Mounting parts: steel, EKB-coated or zinc coated
 Stem / piston rod: 1.4021 (option: 1.4571) rising or non rising

Operation

Handwheel
 Square
 Gear box
 Pneumatic cylinder
 Hydraulic cylinder
 Electric actuator

Accessories

Mechanical limit switches
 Proximity switches
 Solenoid valves
 Positioners
 Stem extensions and pillars

DOMINO knife gate valves Type AT 100/200

High security by cutting effect with the closing procedure

Special executions

Valve with regulation port
 Full bore
 Square valve

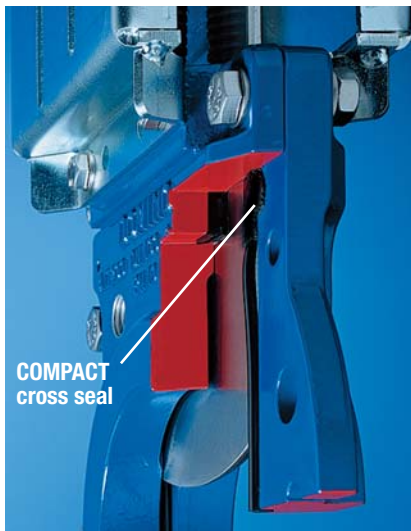

The **maintenance-free COMPACT cross seal (double seal lip profile)** guarantees tight shutoff and can be adjusted without interrupting the working process.

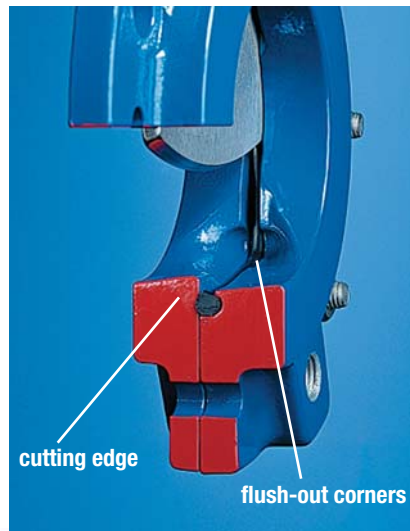

The **self-cleaning effect** is achieved by **flush-out corners** in the body and the cutting edge underneath the gate.
 Solids and fibres are cut by the **cutting edge** before tightening is done against the elastic seat.
 The guidance of the gate is interrupted on stroke length, thus dirt can be ejected.

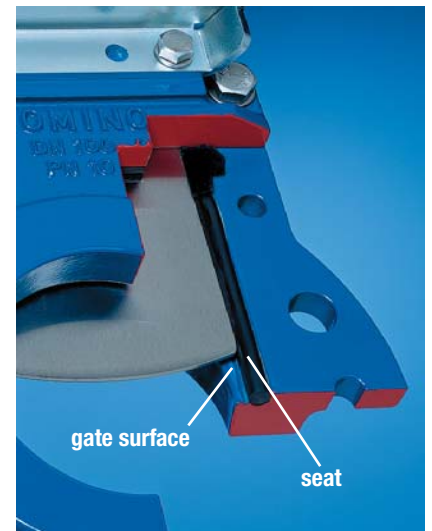

Bidirectional shutoff is achieved by the lateral gate surfaces and the elastic seat which is integrated in the body.

The seat is chambered and prestressed mounted.

The high finish of the guide- and sealing surface at both sides guarantees long service and tight shutoff.

The lateral guidance of the gate prevents the gate from fluttering in either of the flow directions or in throttle positions.





Advantages

Centre-mounted process valve for safe and secure industrial usage

Economic initial equipment with single-piece housing construction

Body complete
Elastomer-lined with seat ring as multifunctional sealing element



Gas transfer station



Butterfly valves Type KG 2/4

High life span by solid seat system



Type KG 2 [DN 50 – DN 300]

Wafer type butterfly valve for installation between flanges DIN EN 1092-1, PN 10/16, ANSI 150.

Technical Data:

Single-piece body, self-centring

Face to face dimensions: DIN EN 558-1 series 20 (DIN 3202-K1)

Top flange: DIN 3337 - ISO 5211

Test: EN12266-1, P10/P11/P12-A

DIN 3230, T3 - BA/BO-1

Control range: 20° - 60° Opening angle



Type KG 4 [DN 50 – DN 300]

Lug type butterfly valve for installation between flanges DIN EN 1092-1, PN 10/16, ANSI 150.

Technical Data:

Single-piece body, self-centring

Face to face dimensions: DIN EN 558-1 series 20 (DIN 3202-K1)

Top flange: DIN 3337 - ISO 5211

Test: EN12266-1, P10/P11/P12-A

DIN 3230, T3 - BA/BO-1

Control range: 20° - 60° Opening angle

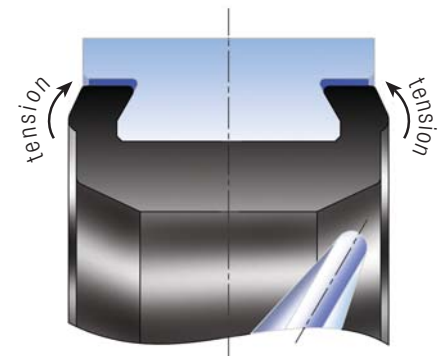

Seat system

The solid heavy-walled seat ring assured absolute leak-tightness and a high life span, also with high flow rates.





GEFA Prozesstechnik GmbH Dortmund is a specialised manufacturing operation in the industrial valve, filtration technology and measurement and control technology sectors. The company was founded in 1964 and was one of the first to carry the three-piece ball valve, soft-seated butterfly valves and pneumatic rack & pinion actuators. In the filtration technology sector, an innovative product line was introduced to the German market by GEFA. The company has been certified since 1992 in accordance with EN ISO 9001 and offers products of the highest reliability and safety. We also have a broad product range available for specific applications. The extensive inventory (5 million euro) guarantees short delivery times.

Legal structure:	Limited company
Ordinary capital:	1.54 million euro
Executive director:	Dieter Maier
Formation and development:	The company was registered in the commercial registry as a limited company on 15.09.1965
Industrial sectors and products:	Industrial valves - Measurement and control technology - Filter technology
Employees:	82 employees
Volume:	Approx. 25 million euro
Business premises:	The office and operational buildings (Germaniastrasse 28 in Dortmund) is owned by the company, office building / workshop and warehouse 5.450 square metres, company property approx. 13,000 square metres
Warehouse:	Approx. 5 million euro

edition: 12-2011

Germany