

Maße Processklappe Serie KG8 Dimensions butterfly valve series KG8 DN 40 - DN 300

Baulänge: EN 558-1 Reihe 20 (DIN 3202-K1) Face to face dimension: EN 558-1 line 20 (DIN 3202-K1)

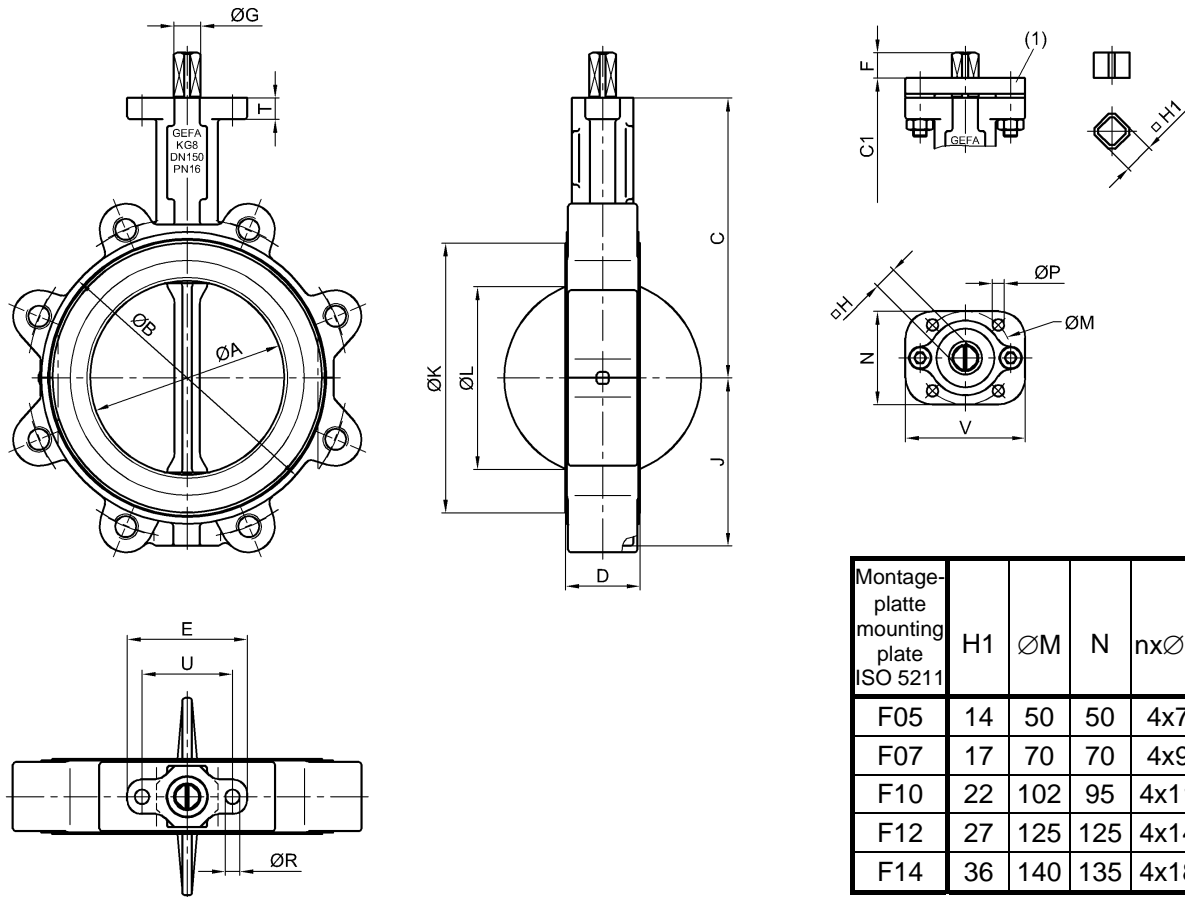

Montageplatte mounting plate ISO 5211	H1	ØM	N	nxØP	V
F05	14	50	50	4x7	90
F07	17	70	70	4x9	90
F10	22	102	95	4x11	125
F12	27	125	125	4x14	150
F14	36	140	135	4x18	150

(1) MULTITOP Montageplatte und Vierkant-Adapter zum Direktaufbau von Antrieben mit größerem Anschlussflansch. Sonderaufbauten möglich.

(1) MULTITOP mounting plate and square-adapter for direct mounting of actuators with larger connection flange. Special designs possible.

ØK = Sitzring-Außendurchmesser / Seat outside diameter

ØL = kleinster Flanschinnendurchmesser / smallest inside diameter of flange

DN	NPS	ØA	ØB	C	C1	D	E	F	ØG	H	J	ØK	ØL	ØR	T	U	kleinster Anschluss min. mounting plate DIN 3337/ISO 5211
40	1 1/2"	52	100	130	145	43*	90	16	14	11	60	86	33	11	14	68	F05
50	2"	52	100	130	145	43	90	16	14	11	60	86	33	11	14	68	F05
65	2 1/2"	64	111	145	160	46	90	16	14	11	67	97	48	11	14	68	F05
80	3"	77	136	160	175	46	90	16	14	11	75	122	64	11	14	68	F05
100	4"	103	163	180	195	52	90	16	16	14	94	147	92	11	16	68	F07/SW14
125	5"	127	193	195	210	56	90	19	20	17	113	176	117	11	16	68	F07
150	6"	146	219	210	225	56	90	19	20	17	126	203	137	11	16	68	F07
200	8"	198	274	240	258	60	125	19	22	17	158	260	191	13	21	95	F10
250	10"	247	328	270	288	68	125	24	28	22	191	313	240	13	21	95	F10
300	12"	299	377	300	318	78	125	24	28	22	222	363	290	13	21	95	F10

* GEFA Baulänge / GEFA face to face dimension

Änderungen vorbehalten
subject to changes