

Maße Drosselklappe Serie KGT Dimensions throttle valve series KGT DN 80 – DN 250

Antriebsanschluss: DIN 3337 / ISO 5211

Mounting plate: DIN 3337 / ISO 5211

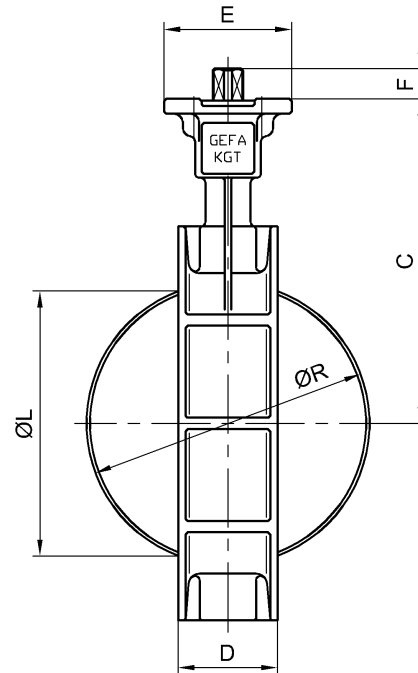
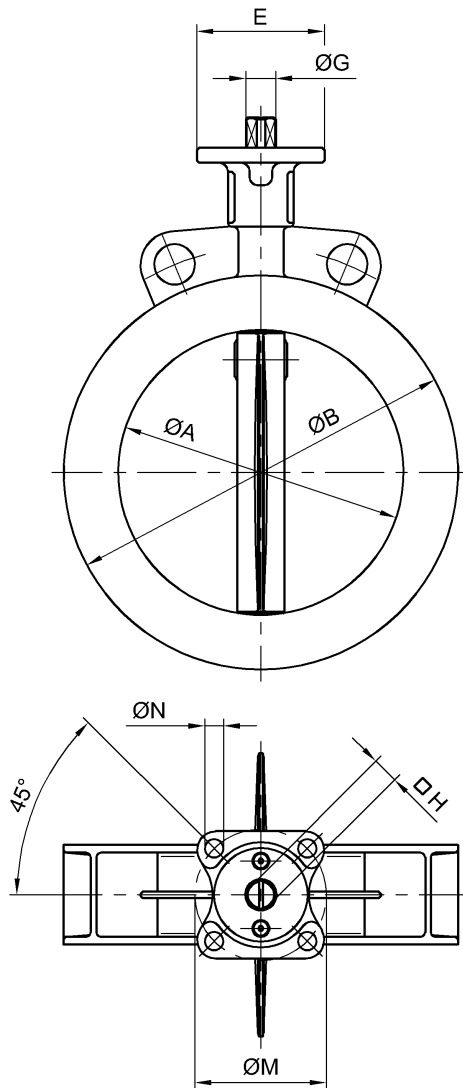

$\varnothing L$ = kleinster Flanschinnendurchmesser
 smallest inside diameter of flange

S = Spaltmaß bei geschlossener Armatur
 Gap dimension in closed position

DN	NPS	$\varnothing A$	$\varnothing B$	C	D	E	F	F*	$\varnothing G$	$\square H$	$\square H^*$	$\varnothing L$	Kopfflansch Mounting plate			$\varnothing R$	S	kg
													$\varnothing M$	$\varnothing N$	ISO 5211			
80	3"	82	135	132	45	68	12	16	14	11	14	69	50	4x $\varnothing 7$	F05	81,3	0,35	2,5
								17			17		70	4x $\varnothing 10$	F07			
100	4"	102	155	152	51	68	12	16	14	11	14	89	50	4x $\varnothing 7$	F05	101,2	0,4	3,0
								17			17		70	4x $\varnothing 10$	F07			
150	6"	152	210	173	53	68	16	17	16	14	17	143	70	4x $\varnothing 10$	F07	150,8	0,6	4,5
200	8"	202	265	211	57	98	19	-	20	17	-	194	70	4x $\varnothing 10$	F07	200,6	0,7	8,5
								22			22		102	4x $\varnothing 12$	F10			
250	10"	252	315	245	67	98	19	-	20	17	-	243	70	4x $\varnothing 10$	F07	250,6	0,7	11,5
								22			22		102	4x $\varnothing 12$	F10			

* Maße inklusive Vierkant-Adapter / Dimensions including square adapter

Änderungen vorbehalten
 subject to changes