

Fig No: MD-28

MATERIALS LIST

NO.	PART NAME	MATERIAL
1	BODY	ASTM A351 Gr.CF8M
4	BALL	ASTM A351 Gr.CF8M
5	STEM	SS316
9	END CAP	ASTM A351 Gr.CF8M
11	BODY SEAL	PTFE.
12	SEAT	RTFE.
13	THRUST WASHER	PTFE.
14	STEM PACKING	PTFE.
15	GLAND	SS304
19	HANDLE	SS304
21	HANDLE COVER	PLASTIC
22	STEM NUT	SS304
23	HANDLE WASHER	SS304
24	HANDLE NUT	SS304
28	LOCKING PAD	SS304
29	BELLEVILLE WASHER	SS304
30	TAB WASHER	SS304
31	O-RING	VITON
32	PACKING FOLLOWER	PTFE.+25%G.F.
33	STOP PIN	SS304
35	BODY STUD	ASTM A193 Gr.B8
37	BOLT NUT	ASTM A194 Gr.8

DIMENSIONS

unit:mm

SIZE	PORT	L	E	H1	H4	C	ØG	ØJ	ØI	T	F	M	ØN	ØK	ØK1	Z	Z1	
DN15	1/2"	15.0	108.0	112.0	8.5	48.0	9.0	89.0	60.5	35.0	11.2	1.6	4	16.0	50.0	36.0	7.0	6.0
DN20	3/4"	20.0	117.0	112.0	8.5	62.0	9.0	98.6	70.0	43.0	12.7	1.6	4	16.0	50.0	36.0	7.0	6.0
DN25	1"	25.0	127.0	136.0	11.4	64.0	9.0	108.0	79.2	51.0	14.3	1.6	4	16.0	50.0	36.0	7.0	6.0
DN32	1-1/4"	32.0	140.0	185.0	11.4	71.0	9.0	117.5	88.9	63.5	15.9	1.6	4	16.0	50.0	36.0	7.0	6.0
DN40	1-1/2"	38.0	165.0	198.0	14.0	76.0	14.0	127.0	98.6	73.2	17.5	1.6	4	16.0	70.0	50.0	9.0	7.0
DN50	2"	50.0	178.0	198.0	13.7	84.5	14.0	152.5	120.7	92.0	19.1	1.6	4	19.0	70.0	50.0	9.0	7.0
DN65	2-1/2"	64.0	190.0	265.0	18.0	106.8	17.0	177.8	139.7	104.7	23.3	1.6	4	19.0	102.0	70.0	11.0	9.0
DN80	3"	76.0	203.0	265.0	18.0	116.0	17.0	190.5	152.4	127.0	23.9	1.6	4	19.0	102.0	70.0	11.0	9.0
DN100	4"	100.0	229.0	325.0	18.0	154.5	17.0	228.6	190.5	157.2	23.9	1.6	8	19.0	102.0	70.0	11.0	9.0

FLANGE DIMENSION: ASME B16.5
FACE TO FACE: ASME B16.10

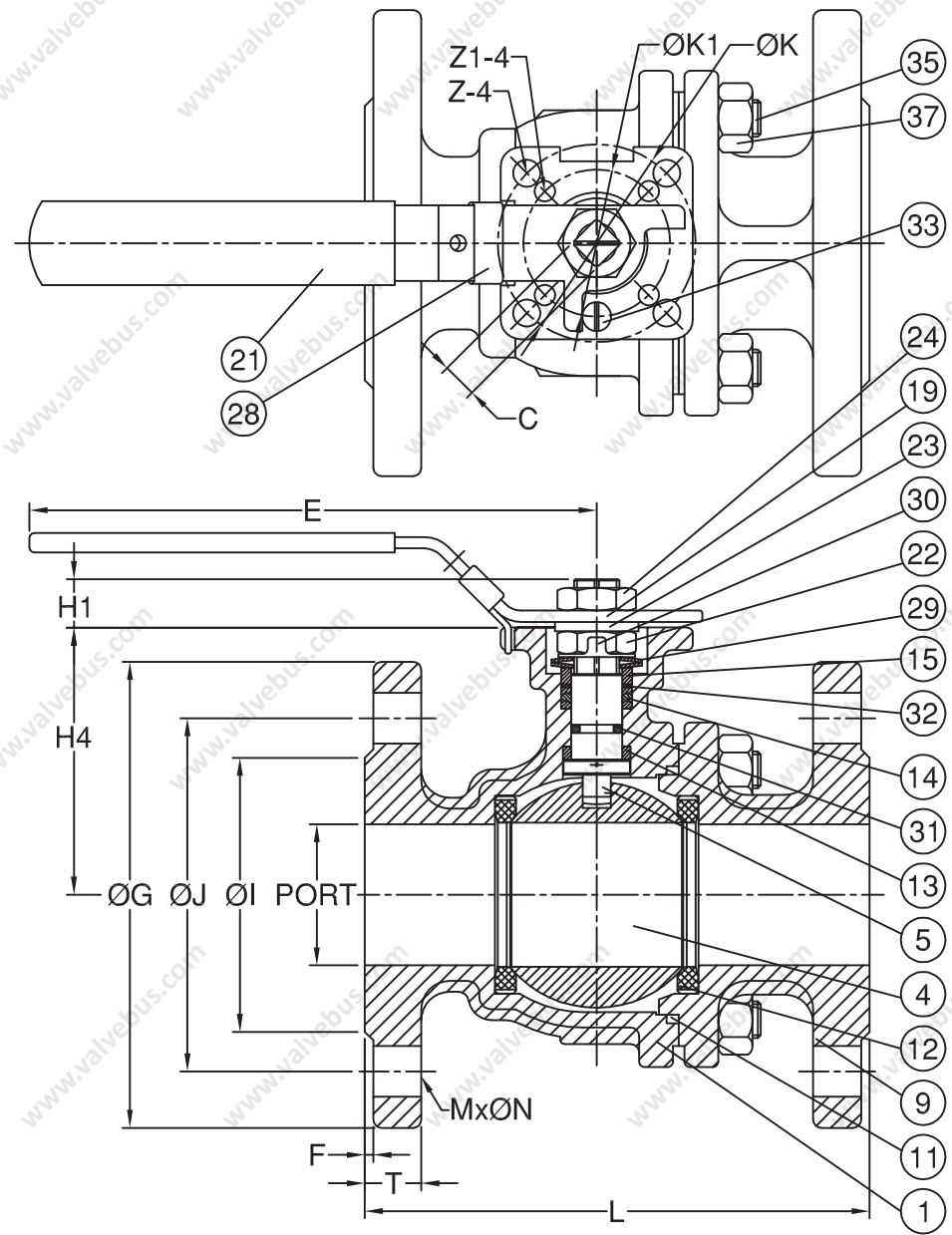

CODE	P-005		APPROVED BY	CHECK BY	DRAWN BY	DRAWING NO.	MATERIAL	UNIT	DESCRIPTION
	INDUSTRIAL CORPORATION	SIGN	MICHAEL	SHANA	SHANA	MD-28-P005	MATERIALS LIST	mm	TWO PIECES BALL VALVES, FLANGED END, FULL BORE, ANSI CLASS 150
			DATE	01/25/2010	01/25/2010	01/25/2010	REVISION	01	

Fig No: MD-28

MATERIALS LIST

NO.	PART NAME	MATERIAL
1	BODY	ASTM A351 Gr.CF8M
4	BALL	ASTM A351 Gr.CF8M
5	STEM	SS316
9	END CAP	ASTM A351 Gr.CF8M
11	BODY SEAL	PTFE.
12	SEAT	PTFE.
13	THRUST WASHER	PTFE.
14	STEM PACKING	PTFE.
15	GLAND	SS304
19	HANDLE	SS304
20	SET SCREW	SS304
21	HANDLE COVER	PLASTIC
22	STEM NUT	SS304
23	HANDLE WASHER	SS304
28	STOP PLATE	SS304
29	BELLEVILLE WASHER	SS304
30	TAB WASHER	SS304
31	O-RING	VITON
32	PACKING FOLLOWER	PTFE.+25%G.F.
33	STOP PIN	SS304
35	BODY STUD	ASTM A193 Gr.B8
37	BOLT NUT	ASTM A194 Gr.8
50	ADAPTER	SS304

DIMENSIONS

unit:mm

SIZE	PORT	L	E	H1	H4	C	ØG	ØJ	ØI	T	F	M	ØN	ØK	Z	
DN125	5"	125.0	356.0	750.0	30.0	194.0	27.0	254.0	216.0	186.0	24.0	1.6	8	22.3	125.0	14.0
DN150	6"	150.0	394.0	750.0	30.0	213.0	27.0	279.4	241.3	216.0	25.4	1.6	8	22.3	125.0	14.0

FLANGE DIMENSION: ASME B16.5
FACE TO FACE: ASME B16.10

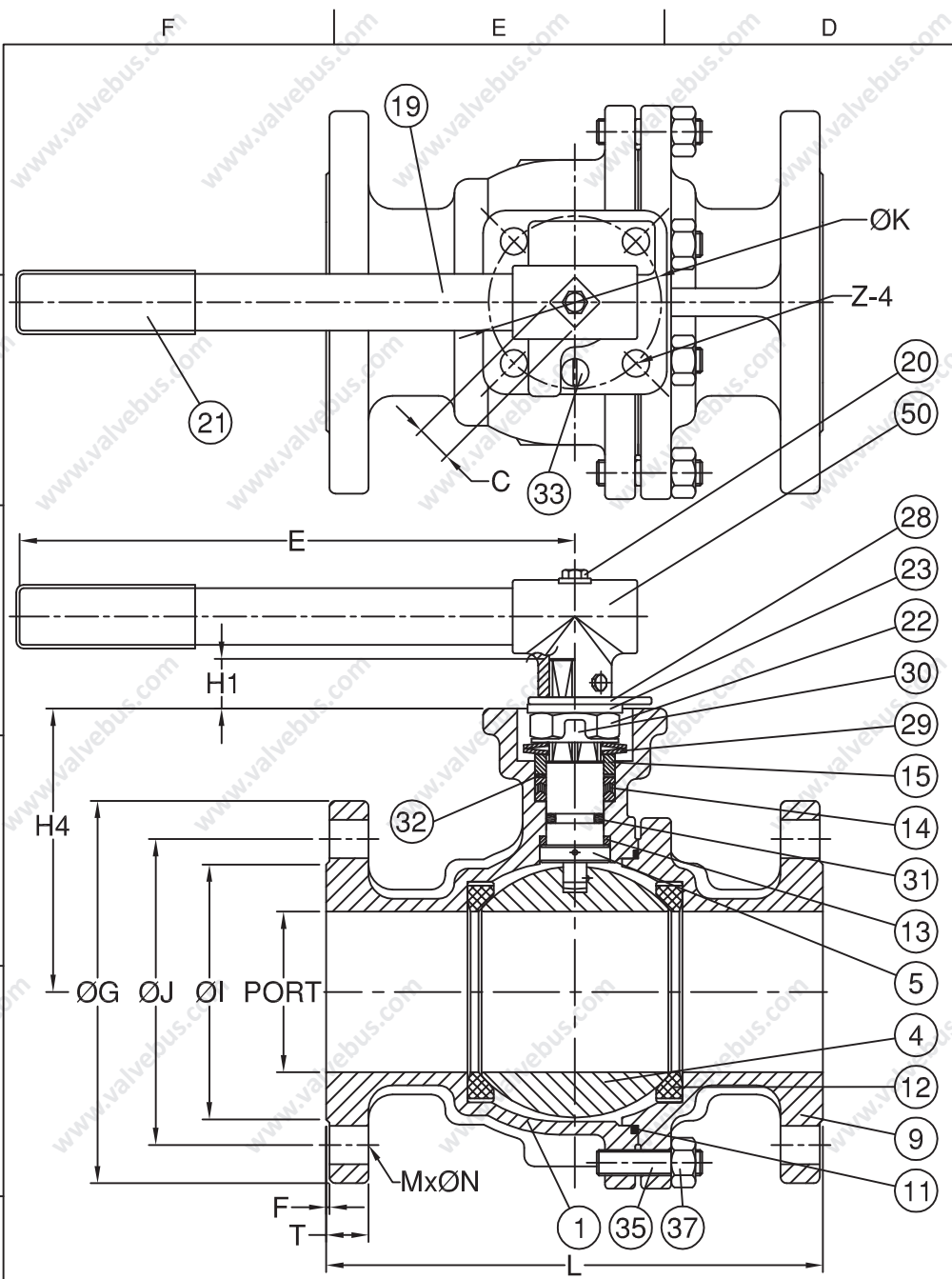

CODE	P-005	APPROVED BY	CHECK BY	DRAWN BY	DRAWING NO.	MATERIAL	UNIT	DESCRIPTION
	SIGN	MICHAEL	SHANA	SHANA	MD-28-P005	MATERIALS LIST	mm	TWO PIECES BALL VALVES, FLANGED END, FULL BORE, ANSI CLASS 150
	DATE	01/25/2010	01/25/2010	01/25/2010	REVISION	01	SCALE	