

Fig No: **SF-2500**

MATERIALS LIST

NO.	PART NAME	MATERIAL
1	BODY	ASTM A216 Gr.WCB
4	DISC	A105N+STL6#
7	DISC COVER	ASTM A276 410
9	BONNET	ASTM A216 Gr.WCB
11	BODY SEAL	SS316
12	SEAT RING	A105N+STL6#
20	RIVET	SS304
25	NAME PLATE	SS304
31	QUARTO RING	A105
35	BODY BOLT	ASTM A193 Gr.B7M
37	BOLT NUT	ASTM A194 Gr.2HM
40	EYE BOLT	ASTM A29 1035
48	PIN	ASTM A276 410
63	HINGE	ASTM A216 Gr.WCB
63-1	HINGE SUPPORT	ASTM A216 Gr.WCB

DIMENSIONS

unit:mm												
SIZE	PORT	L	H	ØD	ØG	ØJ	ØI	T	F	M	ØN	WT(kg)
DN100	4"	72.9	683.0	410.0	157.2	356.0	273.0	203.0	76.2	11.13	8	350.0

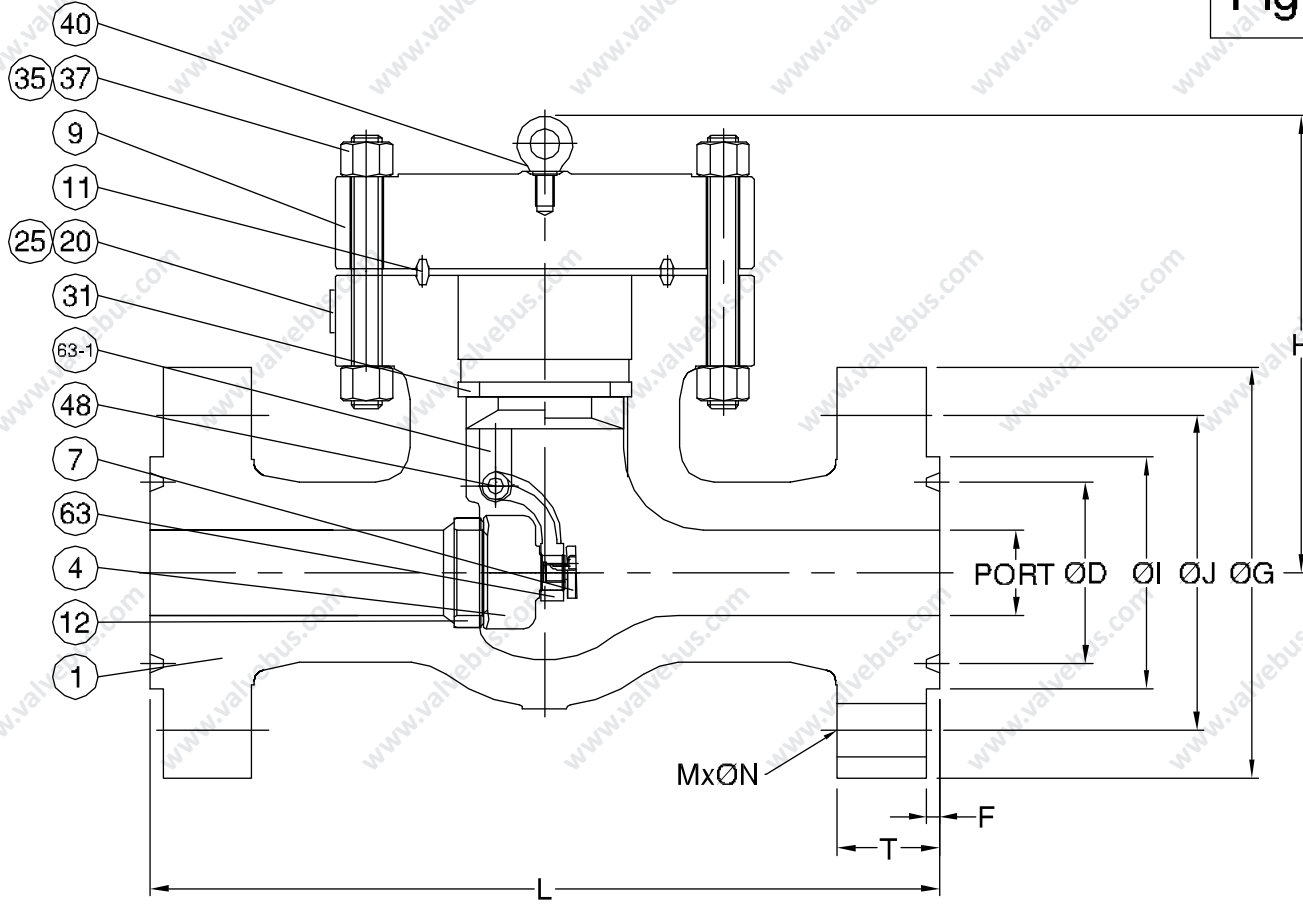

CODE	D-014		APPROVED BY.	CHECK BY.	DRAWN BY.	DRAWING NO.	MATERIAL	UNIT	DESCRIPTION
MODENTIC INDUSTRIAL CORPORATION	SIGN	MIKE	JERRY	JERRY	SF-2500-D014	MATERIALS LIST	mm	CARBON STEEL SWING CHECK VALVE, FLANGED END, ANSI CLASS 2500	
	DATE	03/16/2011	03/16/2011	03/16/2011	REVISION	01	SCALE		FREE